

SFPvh 6501

Laboratory Freezer with Circulating
Air Cooling
Perfection



Freestanding

LIEBHERR

SFPvh 6501

Laboratory Freezer with Circulating
Air Cooling
Perfection

G German
Engineering



Gross / Net capacity	614/480 l
External dimensions in mm (W/D/H)	697/867/2135
Internal dimensions in mm (W/D/H)	489/638/1493
Energy consumption in 365 days	702 kWh ¹
Ambient temperature	+10 °C to +35 °C
Heat output	875 kJ/h
Refrigerant	R 290
Frequency / Voltage	50/60 Hz / 220-240 V~
Cooling system	Dynamic
Defrosting method	Automatic
Temperature range	-9 °C to -35 °C
Gradient / max. fluctuation	3,6 °C ² / 5,0 °C ³
Housing material/color	Steel / white
Door material / color	Steel / white
Interior container material	Chrom-Nickel-Stahl (1.4301 / AISI 304)
Type of control	2,4" color display, touch & swipe
Alarm in case of malfunction	Visual and acoustic
Power failure alarm	Immediately upon power interruption for at least 12 h
Potential-free contact	Yes
Type of connectivity	SmartModule
Interface	WLAN/LAN
Data logger	Integrated, USB interface
Interior lighting	LED light column on both sides, separately switchable
Adjustable shelves	4
Shelf material	Plastic-coated grids
Usable W / D of shelves in mm	480 / 638
Shelf load capacity	60 kg
Maximum total load	240 kg
Castors	Swivel casters with brakes in front, fixed casters in back
Handle	Vertical recessed handle
Sensor port	1 x Ø 12 mm
DIN 13277	Yes
Type of lock	Electronic, with remote control
Door hinge	Right, reversible
Gross / Net weight	150/132 kg
EAN-Nr.	9005382249819

¹ measured at +25 °C ambient temperature and set temperature of +5 °C for cooling and -20 °C for freezing devices.

² Gradient according to EN60068-3: spatial temperature distribution in the interior from the warmest to the coldest measuring point including measurement uncertainty.

³ Max. fluctuation according to EN 60068-3: temporal temperature variation of the measuring point with the greatest difference during the measurement period.

Features

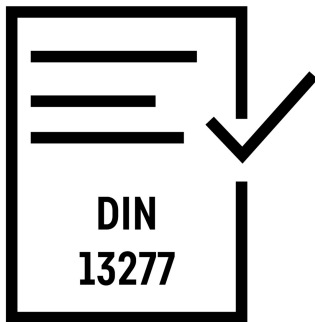

DIN 13277 compliant

Laboratory and pharmacy refrigerators from Liebherr meet all necessary properties and performance criteria to fully comply with DIN 13277. DIN 13277 describes the requirements and test specifications for cooling and freezing devices used in laboratories and for the storage of pharmaceuticals.

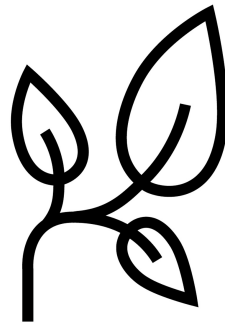

Ultra-efficient

Constantly rising electricity prices require energy-efficient cooling and freezing devices. Liebherr fully exploits the savings potential of all components: from the compressor to the seal to the lighting and electronics. The ultra-efficient devices of the Perfection series show how positively this affects your overall operating cost calculation.



NoFrost Technology

With professional laboratory devices from Liebherr, defrosting is no longer necessary. Moisture is bound by the circulating air cooling, and demand-driven defrost phases remove even the last moisture particles from the interior - for comfortable, safe, and frost-free storage.

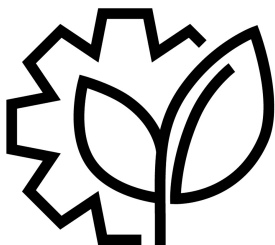

15 Years

Designed for 15 years of use

Sustainability means not only being economical but also durable. High-quality materials in solid workmanship, combined with at least ten years of spare parts availability, make a Liebherr device a robust, reliable, and long-lasting top performer in demanding everyday work.



Alarm relay

In the event of an alarm, the responsible central office is immediately informed, usually through connection to the building management system. In advance, you can determine which alarms should be forwarded, how long the forwarding remains active, and whether a reminder should occur after the alarm acknowledgment. This allows you to react immediately in critical situations.

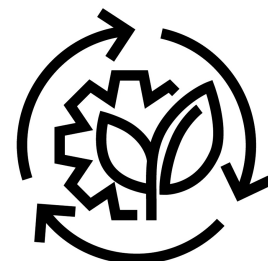

10 Years

Ten years of spare parts availability

Sustainability means not only being environmentally friendly and economical but also durable. To ensure you enjoy your Liebherr device for a long time, Liebherr guarantees spare parts availability for at least ten years. In advance, everything is done to ensure that you do not need spare parts in the first place.

Freestanding SFPvh 6501

LIEBHERR

Technical Drawing

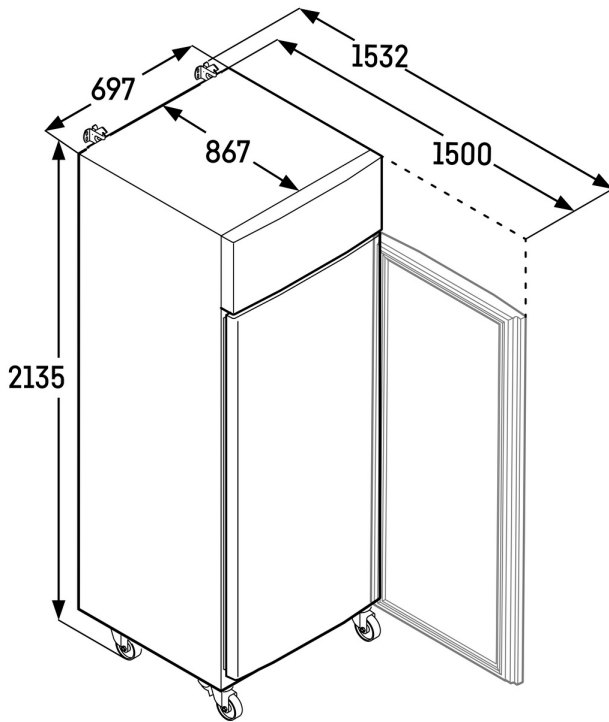

The products and their details are staged for advertising purposes. Although we endeavor to ensure the accuracy of all statements and information in this flyer, Liebherr reserves the right to make changes without prior notice. If the actual device dimensions, specifications and performance are of crucial importance, we recommend checking the installation instructions included with the respective device. Liebherr is not liable for any damage. (03.01.2025)



[home.liebherr.com](https://www.home.liebherr.com)